

SureBuilt

Concrete Forms & Accessories



SURE-PLY

APPLICATION GUIDE

PRODUCT FEATURES

1000 PSF System

All panels are powder coated. In doing so the paint is baked into the panel which allows for a long form-life and easy concrete clean-up.

Exact corner joints eliminate tolerance build-up over large areas.

Angle struts are spaced on 12" centers to provide strength, uniform concrete and minimize deflection.

1/2" plywood is riveted to angle struts. Plywood tolerance is closely maintained to assure long form life.



Side and end rails are rolled from 55,000 p.s.i. steel and welded continuously at corners for maximum strength.

Handles are provided on panels for easy handling in setting and stripping forms

Rear, side and end rail dados are located at 6" on center to allow optimum accessory location.

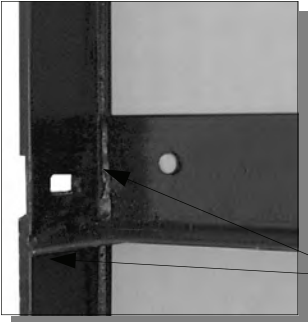
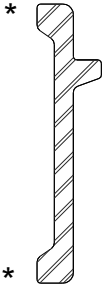

2" wide angle strut allows for more weld for added strength.

* Front and rear rail contact points prevent grout seepage and permit true form alignment with adjacent panels.

INTRODUCTION

What follows is a basic illustration booklet showing the SURE-PLY system's setting techniques, hardware application and it's versatility in reaction to difficult concrete forming projects.

NOTE: *SureBuilt recommends the use of complete safety gear, gloves, safety shoes and protective safety glasses when both erecting and dismantling forms.*

The SURE-PLY forming system has a maximum pour pressure of 1000 lbs./ square foot.

BASIC PANEL AND FILLER SIZES:

Panels: 24" (wide) x 3', 4', 5', 6', 8', 9', 10' (height)

Fillers: 4" to 22" (wide) x 3', 4', 5', 6', 8', 9', 10' (height)

Metal Fillers: 1", 1.5", 2" (wide) x 3', 4', 5', 6', 8', 9', 10' (height)

Inside Corner (metal): 6"x6" & 4"x4" (size) x 3', 4', 5', 6', 8', 9', 10' (height)

Outside Corner: 3', 4', 5', 6', 8', 9', 10' (height)

Filler Angles: 3', 4', 5', 6', 8', 9', 10' (height)

Pilaster Panels: 3', 4', 5', 6', 8', 9', 10' (height)

Culvert Forms: 3', 4', 5', 6', 8', 9', 10' (height)

Inside & Outside Bay Corners: 3', 4', 5', 6', 8', 9', 10' (height)

Hinge Corners: 3', 4', 5', 6', 8', 9', 10' (height)

NOTE: *Forms Available in feet/ inches & metric. (special order)*

Custom forms are available to fit the needs of our customers.

Example: Custom column forms 30" to 24", custom metal fillers 1" to 4" odd sizes, custom culvert forms odd dimensions, custom adapter panel to other forming systems, etc.

Our system fits the needs of the customer with excellent quality, delivery and even choice of colors to make your forms distinctive to your company.

BASIC FORM SETTING

5 STANDARD STEPS TO SETTING:

Step #1

After deciding on appropriate tie spacings insert the wedge bolt through the panel at those tie locations.



Step #2

Now it's time to slide the ties over the extended end of the wedge bolts.

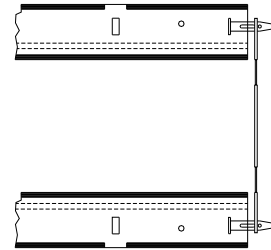

Step #3

Decide which side of the wall you want to work with first, then maneuver the opposing form into position. Take panel "A" and line up the wedge bolt slots with the extended wedge bolts.

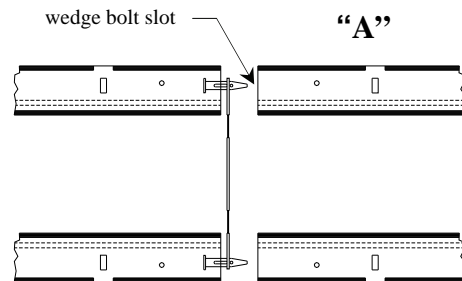

Step #4

Sandwich the wedge bolt between panels by sliding the panels over the extended wedge bolts.

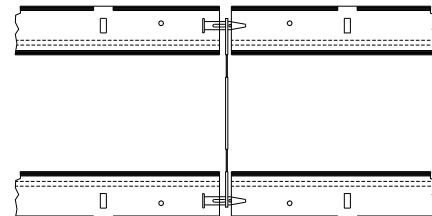

BASIC FORM SETTING

Step #5

Once panels are together simply drop in the tightening wedge bolts. Remember, the wedge bolts should not be hammered down excessively.

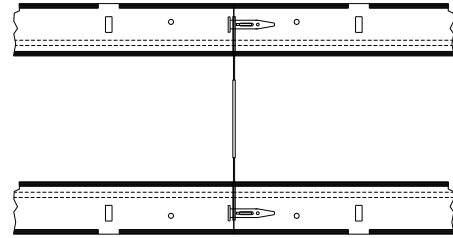

NOTE: Continue panel placement as shown in steps 1-5. After a few panels have been set in place it will be time to attach alignment walers. If stiffbacks & alignment bracing is required this will also be the time to add them. Also, after step 5 you can begin nailing the bottom rail of the alignment panels to the sill. See “SETTING PANELS” below for a better explanation.

SETTING PANELS

Form panels can either be set directly on to concrete or on a lumber sill plate that has been anchored to concrete. The use of sill plates is recommended because it gives a flat surface onto which forms may be set and anchored. Panels should be nailed flush to sill plate edge, at least one nail per panel utilizing nail holes in panel end rails.

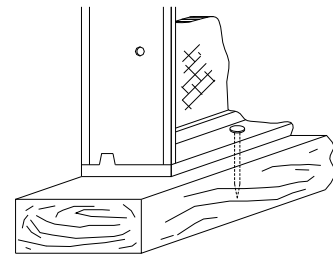

If there is a need to gain a few inches in form height, you can simply add double sill plates. For example, let's say you have 16' and need 16'-3". If you were to use (2) 1-1/2" sill plates you would achieve you desired height. This is an easier approach to adding inches to form height than nailing lumber to the top of the forms.

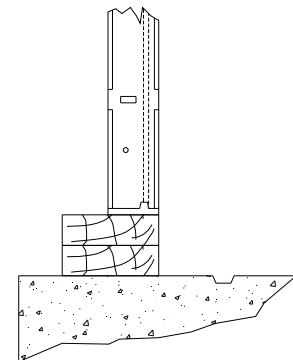

BASIC FORM SETTING

Wedge bolts are used as the basic connection fitting. Two wedge bolts make up a set. One wedge bolt passes thru the rail slot and the second is placed thru the oblong slot of the first wedge bolt, then hammered tight. The wedge bolt set can be used in both vertical or horizontal position.

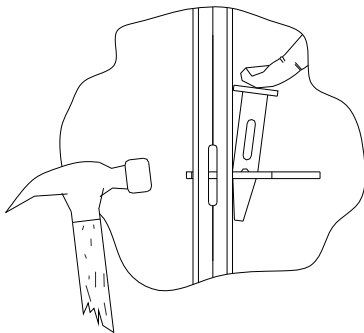
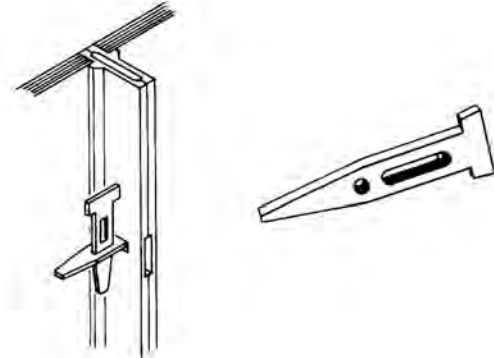

NOTE: *Wedge bolt connections should be tight, but it is not necessary to beat (over-tighten) the bolt. Doing so could cause both damage to forms and make it very difficult to dismantle forms.*

BEGINNING PANEL PLACEMENT

To start, panel placement usually begins at a wall corner or pilaster location. Doing this results in a layout with only one filler form to make up any differences in wall dimensions with outside corner connected to proper panel.

Calculate the first panel by adding inside corner form dimension to the wall thickness. (ex. 6" inside corner + wall thickness of 8" = 14" filler panel. Connect additional panels and ties remembering to level and plumb as you go. Horizontal aligner wales and form aligner braces should be installed as soon as a sufficient number of panels have been erected.

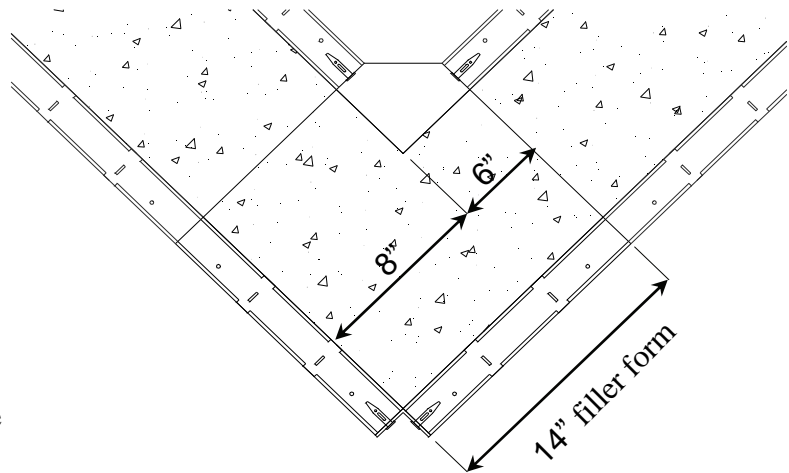

WALERS

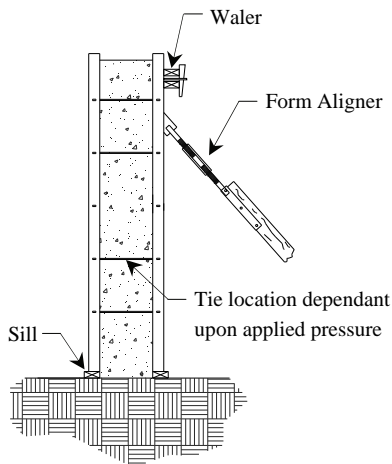

Walers function as an alignment member, keeping forms either straight or following a pre-determined curve or shape. Generally for walls up to 8'-0" height where the panels have been attached to a sill plate only one waler aligner need be attached to top at either the 6" or 18" slot location. Once one side of wall is erected and aligned the opposing wall forms are brought into alignment when the ties are connected between panel sides.

ONE PIECE WALER CLAMP

The one piece waler clamp is the easiest hardware to use. It can hook on to any open side rail slot and can be used to attach either one 2"x4" or a double 2"x4" waler pattern.

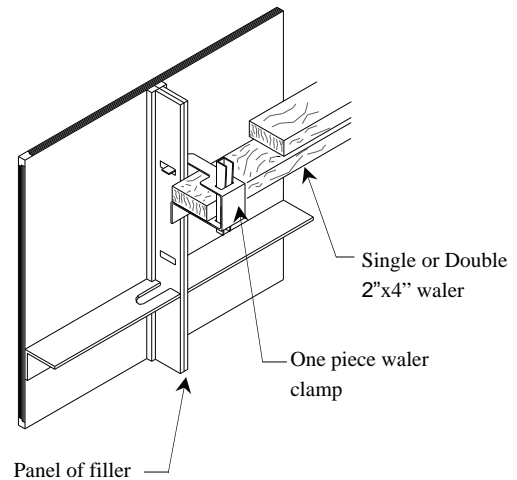

"Z" TIE HOLDER

The use of the waler tie and z-tie holder unit is one that allows the erector more versatility in equipment use since the waler ties come in sizes for 2"x4" and 2"x6". By inserting the proper tie in combination with the standard z-tie holder either size lumber waler can be attached with the use of two standard wedge bolts.

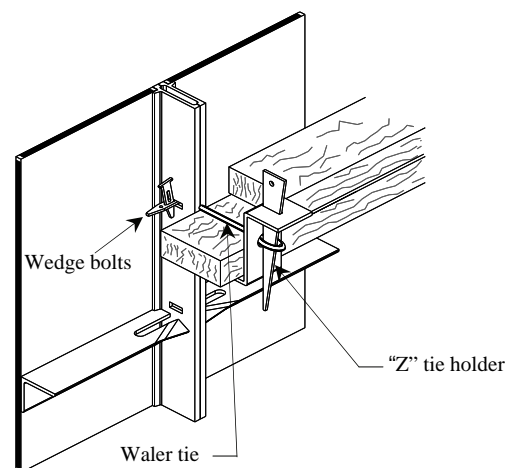

WALERS

J-WALER

The J-Waler hook is one part made up of 3 separate pieces. It can be used in the same locations as any of the other waler brackets. The J-Waler hook works with single or double 2"x4" wood walers.

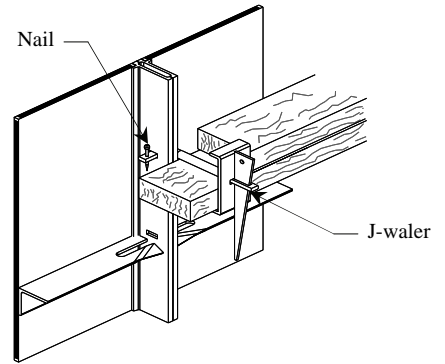

ROLLED STEEL WALERS

In addition to wood walers, Sure-ply forms can be aligned with 3" steel channels and pipe (1 1/2" schedule 40). Both of these steel aligners can be used straight or by being rolled to form circles or curves. The rolled pipe walers are attached to the forms using a pipe aligner hook. The location of the the rolled pipe walers will be the same as regular wood walers. The same applies for the pipe aligner hooks.

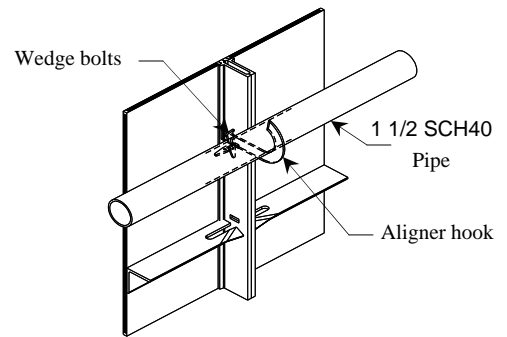

Rolled pipe walers can be lapped and held to the forms with two pipe aligner hooks at the same location. (see detail)

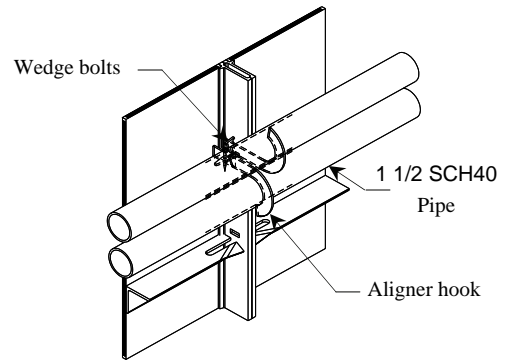

NOTE: Contact SureBuilt for pricing on radius aligners.

!!WARNING!!
PIPE ALIGNERS ARE NOT DESIGNED FOR
LOADING AND MAY CRUSH OR BEND
UNDER LOAD.

GANG WALER ROD ASSEMBLY

The 3" aligner bracket is used in conjunction with a gang waler rod assembly to attach 3" steel channels (C3x5.4). The bracket allows channel to either be run horizontally on top or bellow on the gang waler rods. If there is a need to lap or splice channel use a gang waler plate and the same gang waler rod and nut assembly.

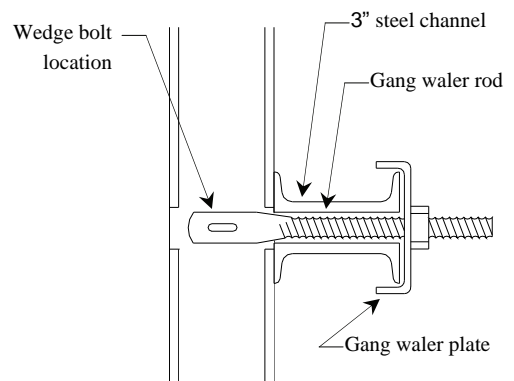

STRONG BACKS

Strong backs are used to align the forms vertically. They are generally used for tall walls or where multiple forms are stacked and waled. Spacing of the strong backs are usually in 4'-0" increments. (Example 8'-0" centers or 12'-0" center spacings.)

Strong backs can be made with either double 2"x4" or 2"x6" lumber. The 2"x6" strongbacks are used when forming requires increased strength.

Strong backs are attached using either strongback ties with "Z"-tie holder or with the "J"-strongback hook. The strongback ties are wedge bolted to the side rail of the form and the J-strongback hook is placed over waler lumber.

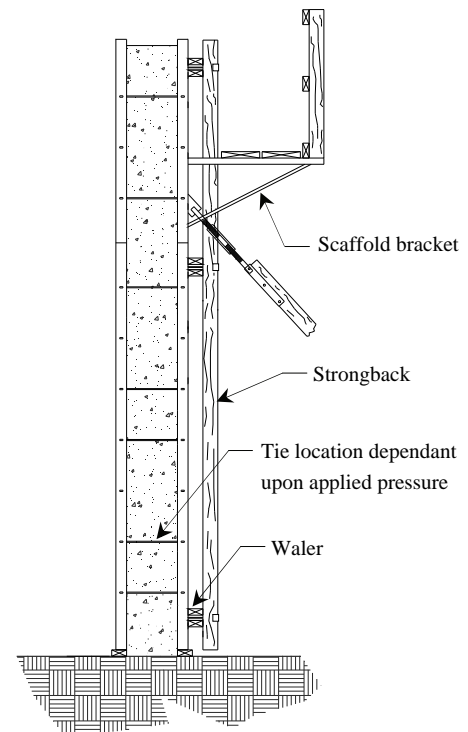

Strongback tie loops are in the same plane compared to waler ties which have loops bent 90° to each other.

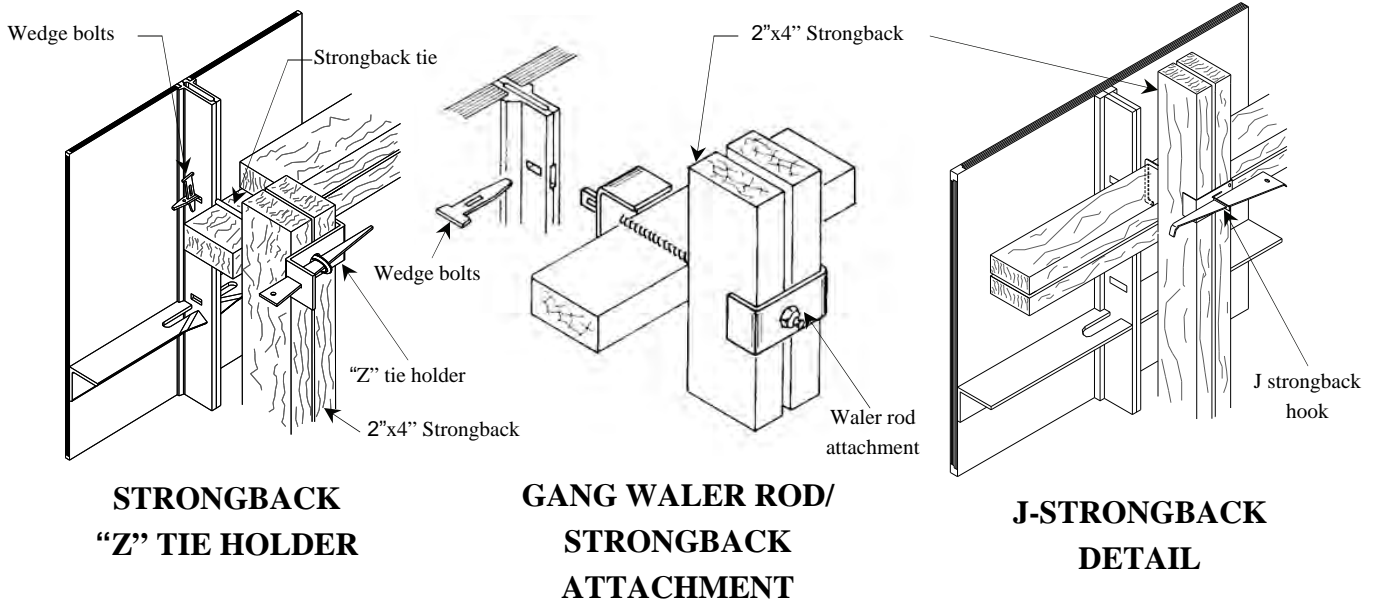

STACKING FORMS

When getting started it's advisable to start erecting forms at a known spot such as a corner location and work your way out. Also, when stacking forms match the same size panel over panel and filler over filler. Doing so will line up your horizontal wedge bolt locations.

Horizontally, use the first and third wedge bolt slots to make panel attachment. The center slot is generally used if a tie is required. Once the first stacked panel is connected repeat the procedure until sufficient wall area has been framed. The opposing wall should be framed with matching panels so that the tie hole locations match both horizontally and vertically.

To achieve a certain height, panels and/ or fillers can be turned horizontally and stacked on top of vertical panels. Attach in the same manner, remembering to leave slot locations for walers, scaffold brackets and/ or miscellaneous hardware.

For more information on stiffening and aligning stacked forms please review the previous sections on walers and strongbacks.

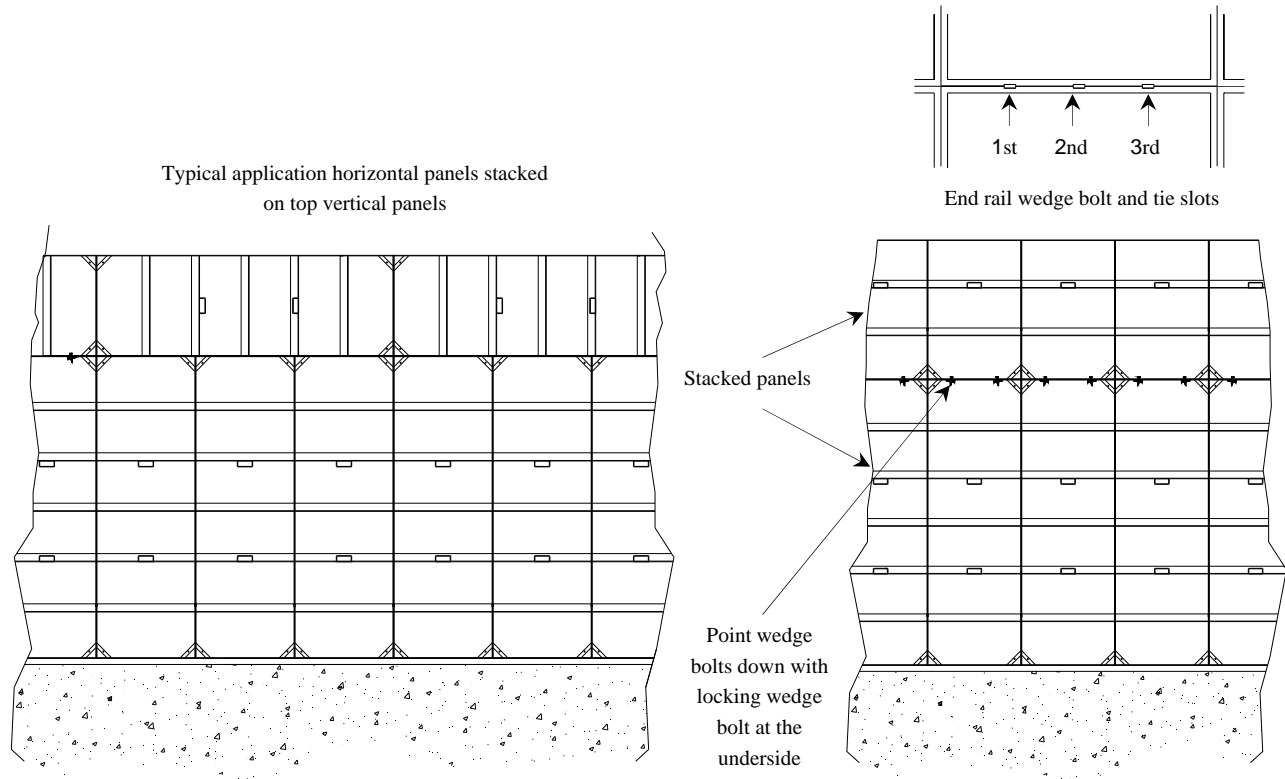

SECOND VERTICAL POUR

There are a variety of methods to frame a second pour of higher elevation.

The first is to embed an anchor into previous pour, strip the forms and attach a lumber sill or ledge to rest the next level of forms on.

NOTE: *During attachment of lumber care has to be taken to maintain level because there is no final adjustment.*

The second method is to leave the top form from first pour attached to wall. The second lift can be erected on top of this form and is fully supported by previous form and ties.

NOTE: *Do not remove or break off ties on top panel. They are the support for second lift.*

The third method is to embed an anchor into previous pour, strip forms and attach an adjustable landing bracket to wall with bolt. A lumber ledge can be placed onto brackets. This gives you both a landing ledge and leveling ability at the same time.

NOTE: *Spacing of brackets and lumber size depend on second lift weight and form configuration.*

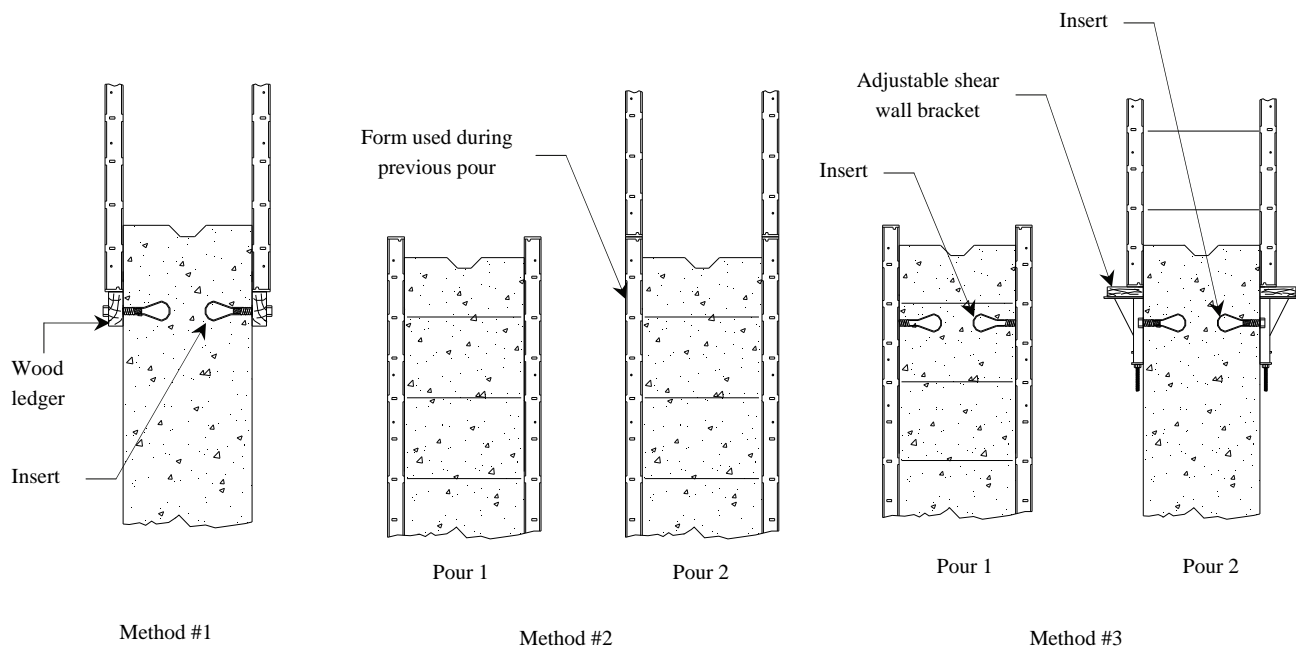

FORM ALIGNMENT

Form aligners are required to position forms straight and plumb. They are never used to hold concrete pressure or any other load. Depending on forming requirements, there are several methods to align forms.

The first method is steel or wooden stake along with attachment plate and lumber aligner all nailed together. There's no adjustment with this method of form aligning.

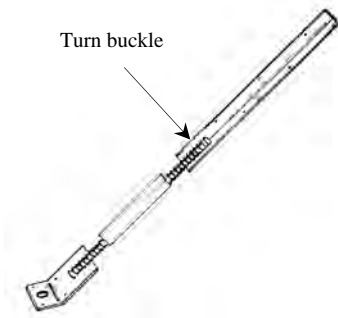
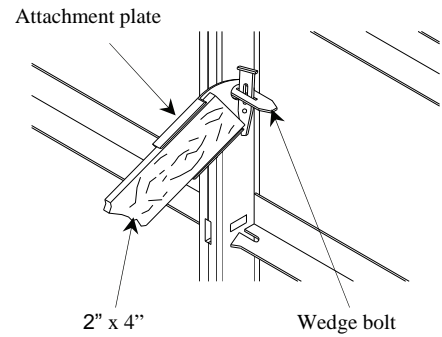
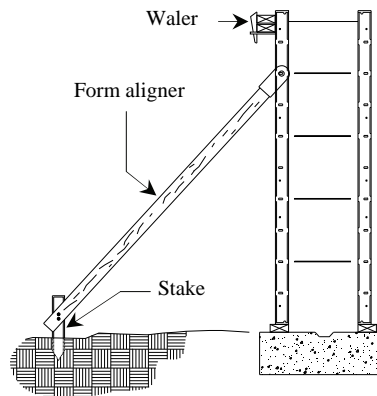

The second method is the use of an adjustable turn buckle form aligner. Again, use attachment plate and wood aligner, but it is nailed to the turn buckle and allows contractor to adjust a maximum of 6".

The third method of form aligning is handled by using Sure-ply's tubular steel mini brace. It is made with standard stake foot on one end and has a Sure-ply attachment plate on the other end. It extends from 7'-6" to 11'-6" and at each setting allows you 12" of adjustment.

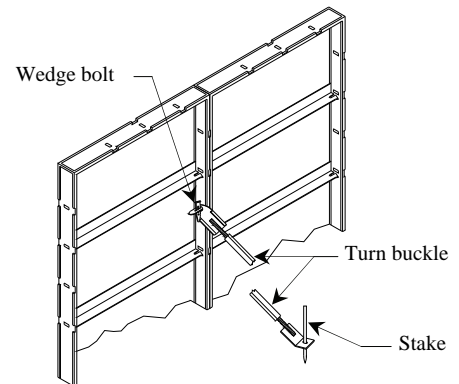

The final method is for tall walls or column forming. Standard pipe brace ranging from 14'-0" to 39'-0" are available.

NOTE: Depending on application SureBuilt can manufacture any style attachment hardware you require.

SCAFFOLD BRACKETS

Scaffold brackets are installed when and where personnel are required to work at elevated levels to perform necessary work installing both forms and concrete. This scaffold bracket is designed for worker access only and has a rating of 500 LBS. The maximum spacing is 8 ft. on center.

Scaffold brackets are not to be used to support concrete, equipment or construction materials. They are secured with wedge bolts and special s-wedge that has been attached to the bracket.

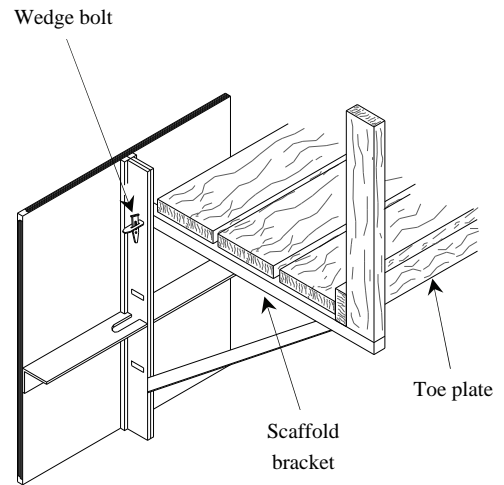

NOTE: *Scaffold brackets attach to the forms only, never to ties and the s-wedge must be used to make connection.*

SAFETY EYE

Climbing formwork is not a recommended procedure, but may be necessary in some situations. The safety eye is designed to attach to the Sureply form with standard wedge bolts at previously set points and provide a secure hook point for attachment of safety work belts.

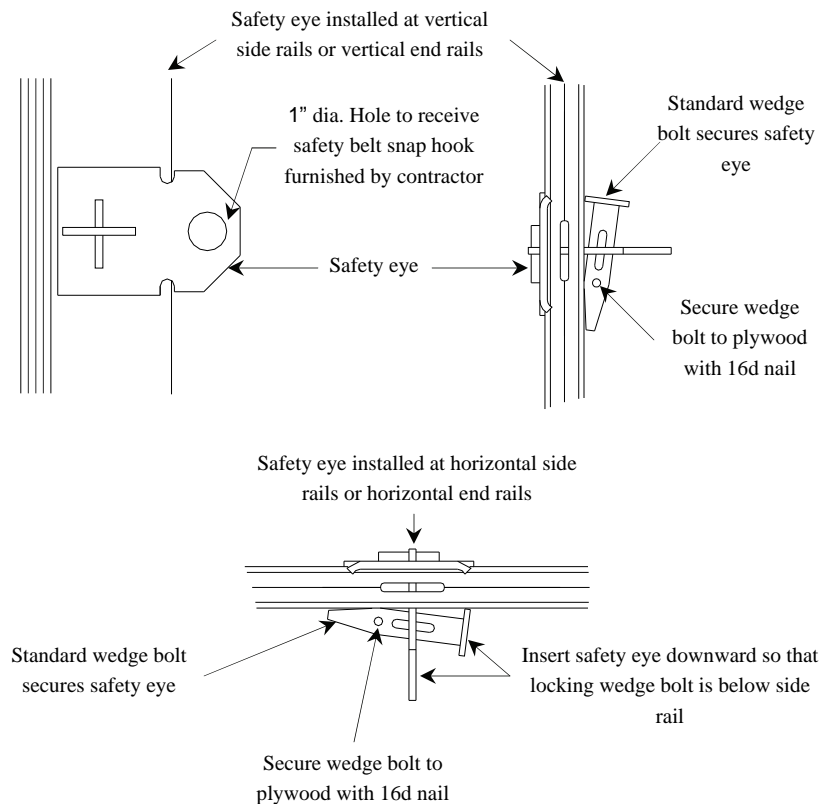

FILLERS

3 DIFFERENT FILLERS TYPES:

- Steel Filler Panels (wood-faced)
- Metal Fillers
- Job-Built Fillers (filler angles)

FILLER PANELS

UNI-PLY filler panel sizes are available in all even increments from 4” to 22”. Filler panels are manufactured with the same materials used to make standard 24” wide panels.

Ties are used on both sides of fillers

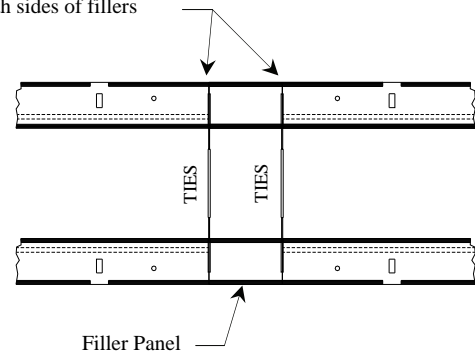

METAL FILLERS (1”, 1-1/2”, 2”)

Metal fillers come in 1”, 1 1/2” & 2” widths with tie slots centered on the metal face at 12” centers. They are connected to opposing forms with either long bolts or adjustable long bolts.*

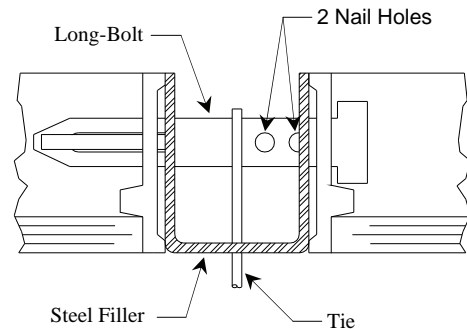

**Long bolts are punched with (2) 1/4” holes. These holes are designed to accept a 16d, 20d, or broke-off panel tie end to shorten the long bolt to accommodate a 1” or 1-1/2” metal filler. 2” metal fillers can use a regular wedge bolt with the long bolt.*

JOB-BUILT FILLERS (Filler Angles)

Filler angles are a great way for the contractor to quickly make up odd dimensions in forming layout. Filler dimensions can be from 3” to 12”. Filler angles attach to panels with standard wedge bolts. The 3/4” strip of plywood filler strip can be attached to the angles with the use of screws or nails.

JOB-BUILT FILLERS

Ties are to be on both sides of the filler angles as shown in figure 1. Because there is no embossment to these filler angles, one must use flat ties next to the filler angles. However, it is possible to use wire ties by leaving a 1/8" gap between the filler angle and the panel as shown in figure 2.

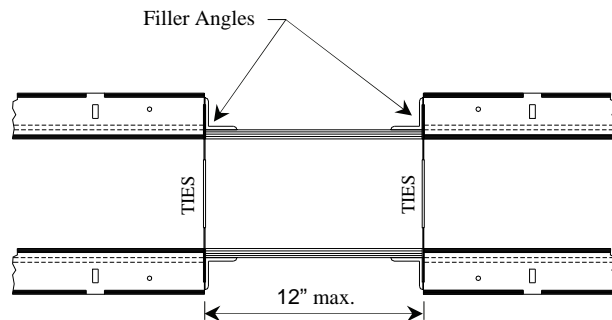

FIGURE 1.

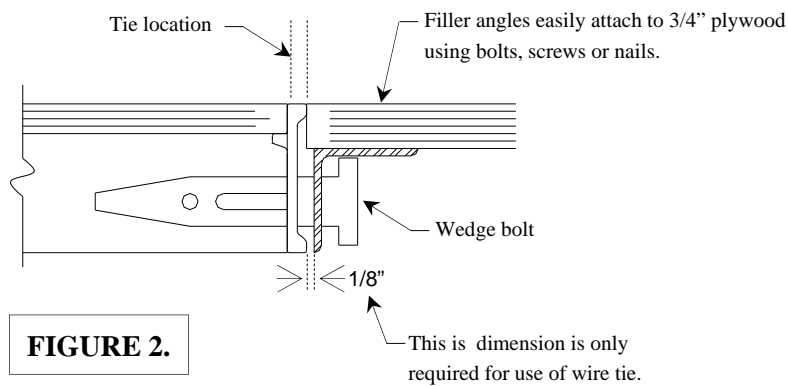
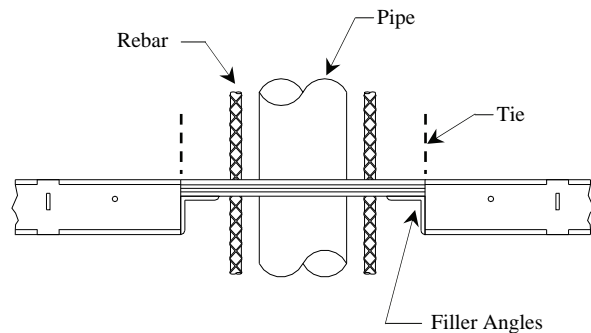
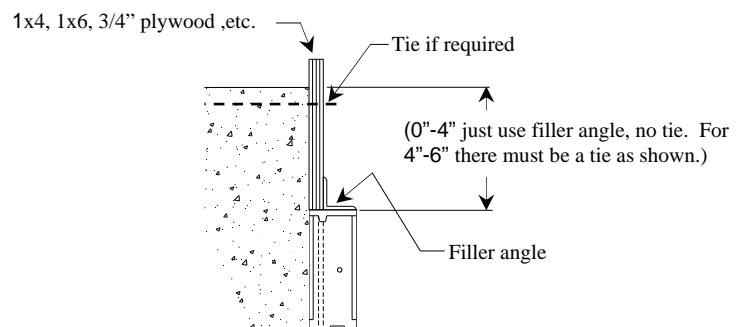

FIGURE 2.

Creating “job-built fillers” can be very beneficial when forming around protruding objects. Whether it be various pipes, rebar, etc. job-built fillers is a quick fix to the situation.



Filler angles can also be used to add a few inches to the top of the form to achieve the desired wall height.



BASIC FORM SETTING

TIE OFFSETS

When designing the layout for concrete formwork often times there are situations where panel joints don't line up with those on the opposite side of the wall. Often times this situation can be handled by pulling the tie at an angle to the opposite form joint. The tie can have a 1" horizontal offset for an 8" wall and 2" for 16" wall. The offset to wall thickness ratio must not exceed 1:8. Exceeding this ratio will void the integrity of the tie.

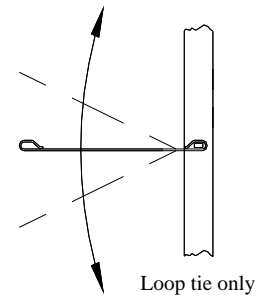
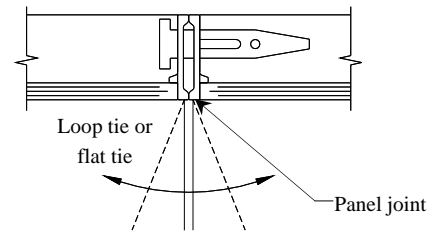

As shown here ties can also have a vertical offset. The same rule applies to the horizontal offset. The ratio of the offset to the wall thickness is 1:8. Likewise, exceeding this ratio will void the integrity of the tie.

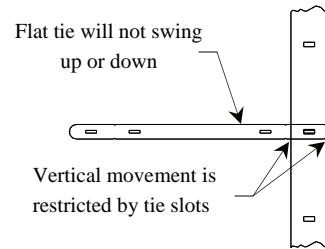

WALL INTERSECTIONS

Sure-ply offers two sizes of Inside Corners 6"x6" and 4"x4". Whether you have an intersecting t-wall or a pilaster, the following will work for both situations. If the perpendicular wall is 12" or less, one panel or filler will be on the back side of the intersecting wall.

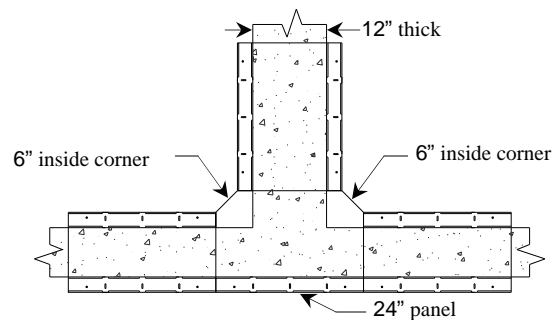

If the perpendicular wall is 14" to 16", we can still form this without any added bracing. This can be done by using a panel with a metal filler on both sides. In doing so we may need to refer to the tie offset section above.

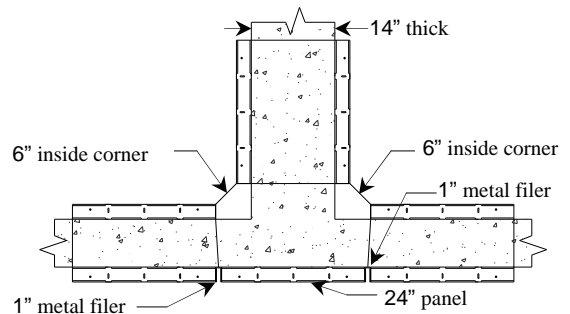

wall intersections cont. →

BASIC FORM SETTING

WALL INTERSECTIONS

If the perpendicular wall thickness is greater than 16" we have a couple of options. One option is to use a pre-bent tie on both ends of the back panel. Another option is to use two fillers on the back side of the intersecting wall. The joint of the two fillers should be roughly centered on the intersecting wall and waled and/or braced as needed.

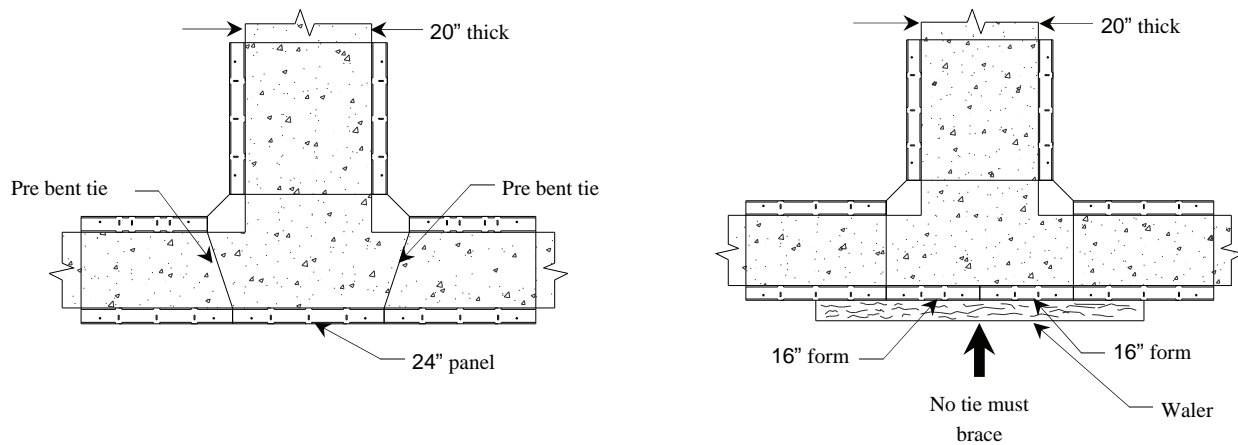

PILASTER FORM

Pilaster forms are all metal forms that are adjustable from 1" to 12" in even and odd increments. The face of the pilaster form is punched with slots for the perpendicular panel or filler to attach.

The dimension from the end of the pilaster form to the first available slot is 2". The dimensions increase in even increment, such as 2", 4", 6", etc.

However, if an odd dimension is required simply flip pilaster form. The dimension from the face of this side and the first slot location is 3". These dimensions increase in odd increments, such as 3", 5", 7", etc. This is best understood by reviewing the details shown here.

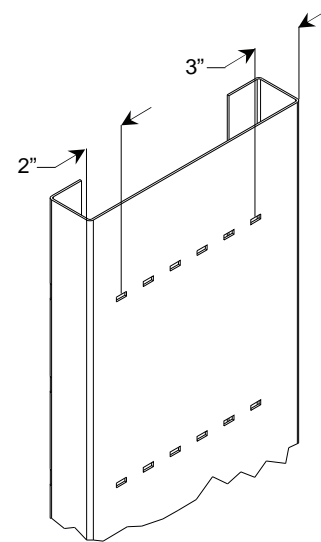

pilaster form cont. →

BASIC FORM SETTING

PILASTER FORMS CONT.

When designing the form layout it's important to remember the pilaster face dimension is 3". So, in order to figure out the size of the form for the back of the pilaster you add the face of the pilaster plus 3"+3".

Refer to the previous "wall intersections" section to figure out tie and panel/ filler layouts.

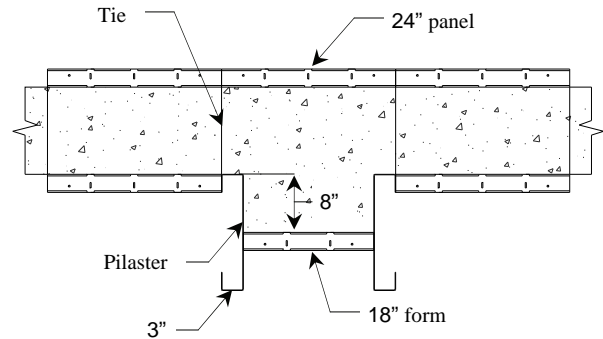

PILASTER DESIGN WITH PANELS AND/OR FILLER PANELS

Pilasters can also be form using standard fillers and/or panels with 6" and/or 4" inside corners. This method of forming pilasters is much like that of intersecting walls. Refer to that section if needed to determine filler sizes and tie layouts.

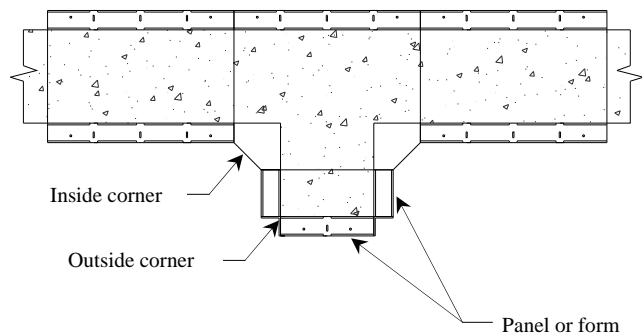

PILASTER BRACE

If the pilaster depth dimension becomes very large it is recommended that a corner brace be used to maintain 90° to wall dimension. Example shown here.

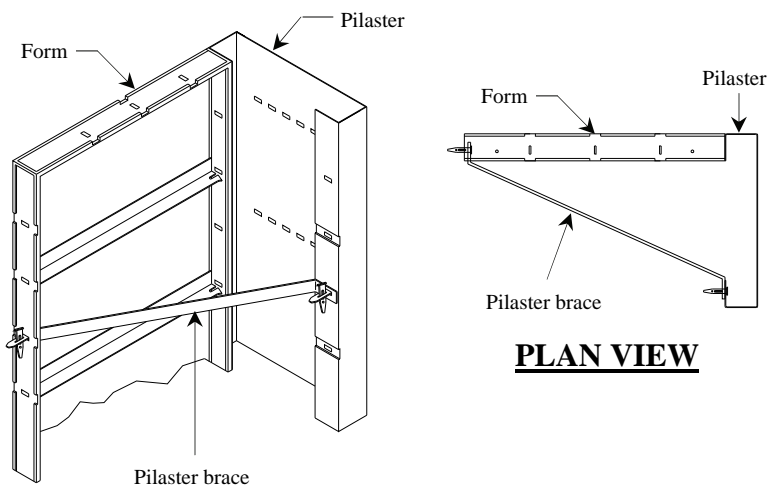

FOOTINGS (FORMING, STEP & SLOPING)

FORMING FOOTINGS

Footings pads, slab edge, grade beams can all be framed with the use of footing corner brackets and stake pockets. By attaching two corner brackets with wedge bolts top and bottom you can make any size required in 2" increment. The stake plates are attached to top rail of form as required and the appropriate length 3/4" dowel is driven in to ground.

STEP FOOTING

Footings steps usually occur at random locations and vary in heights. If the rise of the steps are 6" or 12" a normal panel connection with wedge bolts can be made. Due to scarf tie locations on panels, flat ties may have to be substituted for loop ties where they occur. If the footing drops in some other even dimension other than 6" or 12" a 2" metal filler can be used at this location since their slots are punched at 2" increments. Connections are made with long bolts and wedge bolts and tie go through the center of the metal filler.

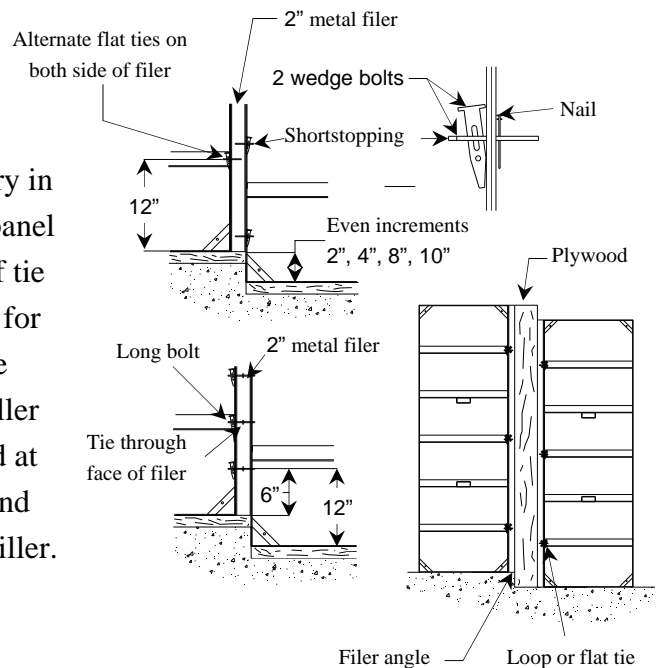

SLOPING FOOTING

Sloped footings can be attacked in a couple of ways. Forms could be stepped with a triangular blockout used to create the slope. (see detail)

Another way would be to rotate the forms perpendicular to the slope. As the forms come down the slope a wedge shaped filler can be used to transition from sloped to straight. (see detail)

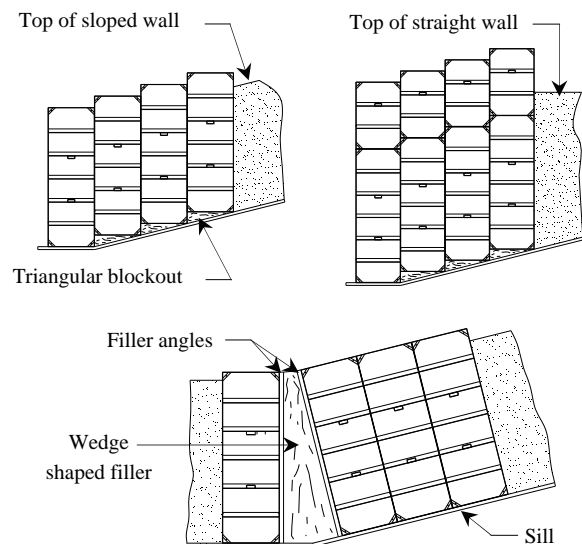

CAPPING OFF WALL POUR

BULKHEAD FORMING

Bulkheads can be formed many ways. There are three we recommend. **The first method**, and probably the easiest, is to wedge bolt an outside corners to a filler panel. The filler panel acts as a cap for the wall. It's the same size as the wall thickness (ex. 12" wall use a 12" filler panel).

The second method is to cut 3/4" plywood to width of wall. Then, nail at least 2 pieces of 2"x4" lumber to the face of panels. Afterwards, compress and lock ties and brace if necessary.

The third method involves the use of ply-lags and gang waler plates. Cut desired width of 3/4" plywood and nail vertical 2"x4" 's perpendicular to the plywood. Insert this wall cap between forms. So, looking in plan view now you should see a piece of plywood (ex. 12" strip for 12" wall) with vertical strongbacks supporting the plywood.

Now you need some type of waler to support the strongbacks. This could be double 2"x4" horizontal walers. Wedge bolt ply-lags perpendicular to these walers and lock with gang waler plates and 1/2" coil nuts. Ties can still be used to maintain wall width.

Each project is unique some bulkheads have keys, water stop, etc. As to the method you choose, remember to make a strong closure because the pressure is always constant.

HY-RIB FOR CONSTRUCTION JOINTS

Hy-rib is a permanent steel mesh form used to form construction joints. It's unique because of it's durability, low cost and ease in using. Hy-rib has too many qualities to list here. This is an exciting time saving product you do not want to miss out on. For a detailed brochure please contact your local sales representative or one of the SureBuilt distributor in your area.

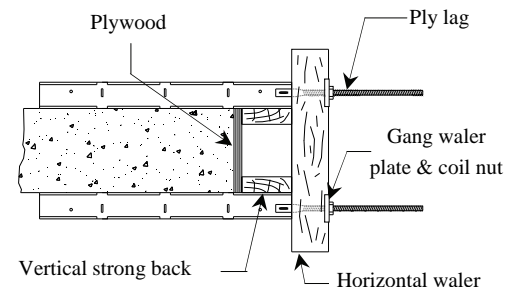
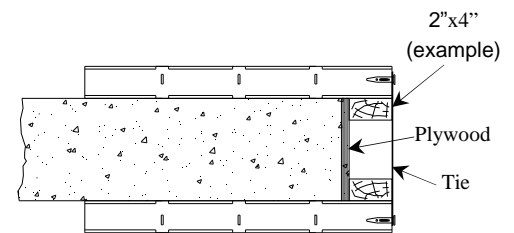
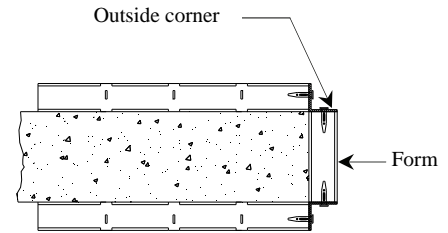

LEDGE BRACKETS

CANTILEVER BRACKET

The Cantilever Bracket is used for suspending the formwork on one side of the wall from the opposite side. This is used when pouring a slab with an up-turned beam edge or curb monolithically.

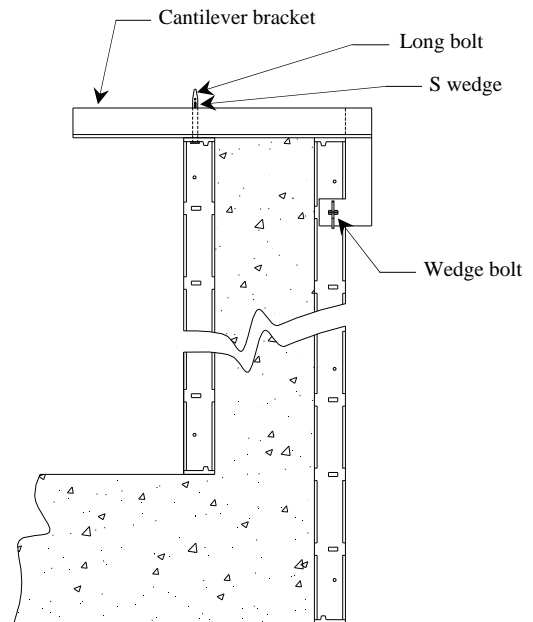

BRICK LEDGE BRACKET

The Brick Ledge Bracket is used for supporting a box out where a brick ledge is required. It can also be used to support a second lift of forms for the brick ledge.

Brick ledge box outs are usually built with sheathing attached to vertical lumber. The vertical lumber is nail or screwed to the brick ledge brackets. The brick ledge bracket is easily attached to the forms using standard wedge bolts.

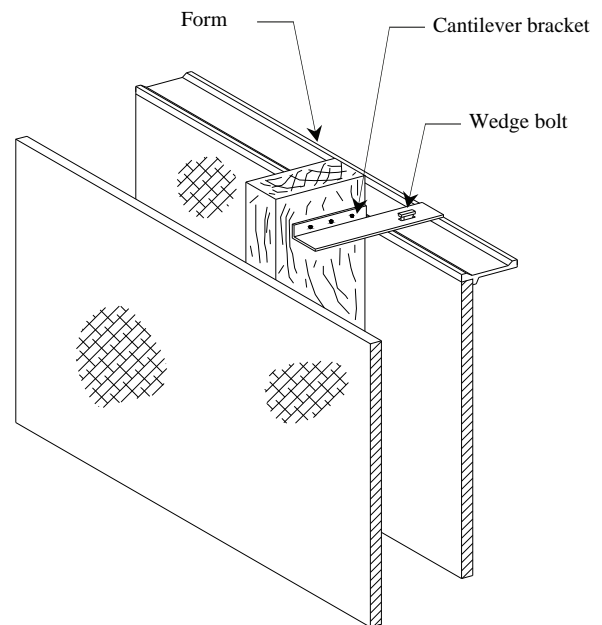

Box out sizes and designs will vary according to architectural requirements.

BATTERED WALLS

Battered means one or both sides of walls are leaning in. Within the industry, **single batter** is when one side is straight and the other is leaning in. **Double batter** is when both sides are leaning in.

Ties vary in length from the longest at bottom to shortest at the top. All framing is the same as normal except battered walls need to be anchored down to compensate for up lift.

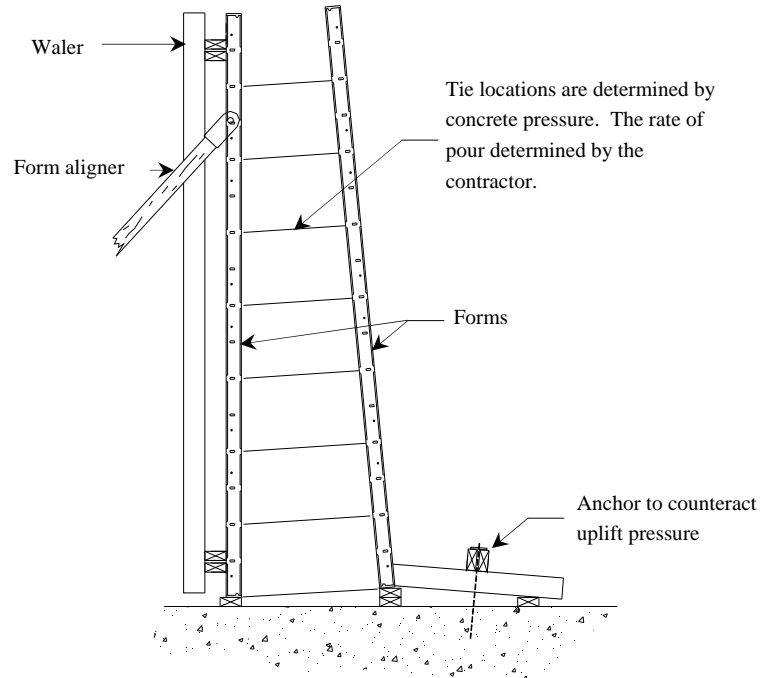

NOTE: *Wire ties may have to be bent to fit some battered walls.*

OUTSIDE/ HINGED/ BAY/ CORNERS

OUTSIDE CORNERS

Outside corners are steel angles used to attach perpendicular outside forms. The outside corner is attached to the forms with standard wedge bolts. These wedge bolts are placed at the same elevation as the ties. To avoid hitting wedge bolts when attaching to the forms insert the wedge bolt from the outside corner toward the form. This way the perpendicular wedge bolt can bear on the cross member and the adjacent wedge bolt has clearance.

BAY CORNERS

There are two types of **inside bay** and **outside bay corners**. Both are all metal faced fixed 135° corners. The inside bay has a 3"x3" face dimension and the outside bay is 7"x7". By using these with both panel and filler forms most combinations of 45° corner can be formed. The width of wall is the determining factor as to filler requirements.

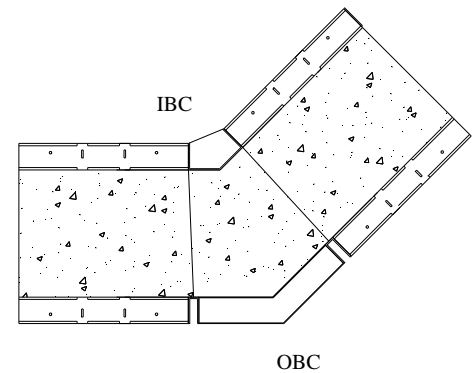

HINGED CORNERS

The **inside hinge corner** is used to form inside corners that have a minimum angle of 45°. It's face dimension is 6"x6". The inside hinge corner can also be used as the outside corner if needed.

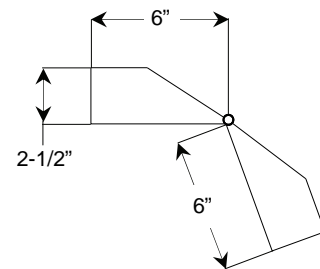

The **outside hinge corner** is used to form outside corners as sharp as 5° minimum to a maximum of 135° fully opened. Wedge bolts may prevent the outside hinge corner from fully opening. With this in mind the wedge bolts should be inserted from outside inward.

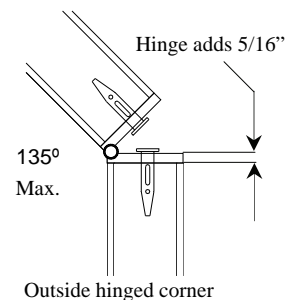

Due to the nature of hinges they should be waled, braced and/ or blocked into their final position. They should never be used for column applications.

COLUMN FORMING

Column forming presents its own set of problems due to the rate of pour and liquid head pressures achieved.

When framing columns the outside corner angles have to be wedge-bolted not only at 12" cross-member level, but also at the 6" center locations. Doing so creates a continuous connection along the outside corner.

To assist contractors with column forming, SureBuilt has developed both panel and filler column forms with cross-members at 6" centers for additional strength.

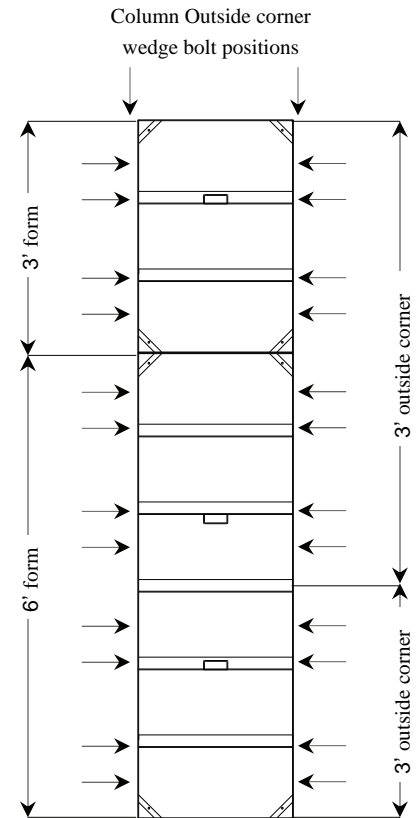

COLUMN HARDWARE

Column Hinges are used to hinge forms during setting and stripping. Quick Column Hardware, used opposite the Column Hinges, allows the forms to be opened with hardware still in place. Used together, this column hardware speeds column production and increases labor productivity.

CULVERT FORMS

Culvert forms come in standard sizes of 9"x9" and 12"x12". These are available in 3', 4', 5', 6' & 8' lengths.

NOTE: *SureBuilt can fabricate custom culvert forms to fit your job-site situation. Pricing will vary so please contact your local sales representative or SureBuilt distributor for more information.*

Culvert forms are used to create the angled corner of box culverts. Culvert forms can be treated like a normal form in that they wedge-bolt together and can be tied where required.

Box culverts are usually formed monolithically. Panels and fillers can be used to form the slab bottom. However, adequate shoring must be supplied to support the total design load (live load + dead load).

Another method of shoring would be to first bolt a filler angle to the culvert form. Then, use plywood across the bottom of the slab supported by typical shoring equipment (frames, beams, stringers, etc.).

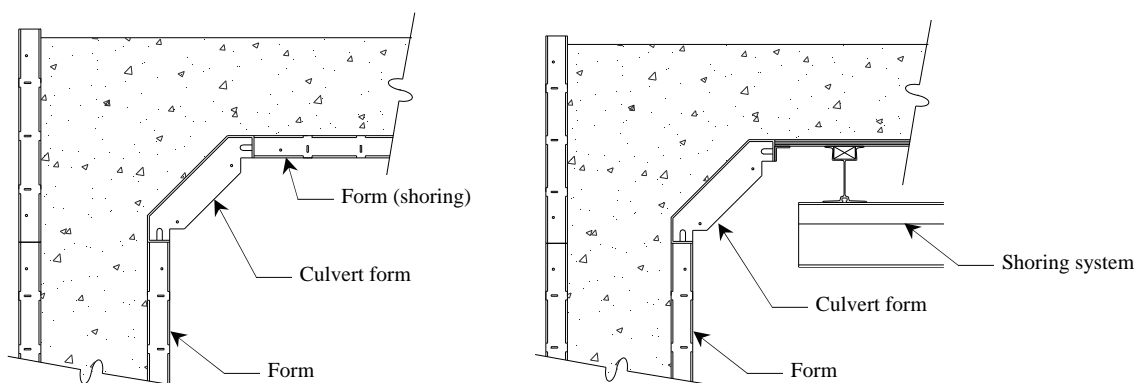

CURVED/ RADIUS WALLS

Sure-ply can perform most radius using a combination of either panels, fillers panels and metal fillers. The degree of offset or flat, compared to the round, dictates panel size and what is an acceptable wall finish. This is referred to as the “chord offset”. The chord offset is typically 1/4” maximum.

As one can tell, the outside radius circumference will be larger than the inside. Therefore, by making up that difference at each panel or every other panel, tie locations can be maintained directly opposite each other.

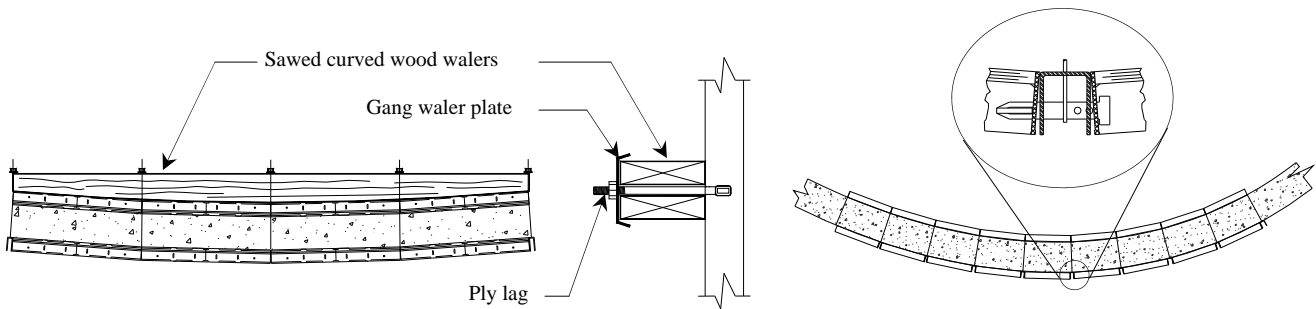

Radius walers can be made of a variety of material and attached with standard uni-ply hardware.

1. Saw cut 2x8, 2x10 or 2x12 lumber and attached with ply lags and gang waler plates.
2. Lumber flexed the soft way and layered with three layers of 1”x6”.
3. Rolled 1 1/2” O.D. pipe attached with pipe aligner hooks.
4. Rolled 3” channel attached with channel aligner bracket.

NOTE: Custom rolling available at SureBuilt Concrete Forms and Accessories.

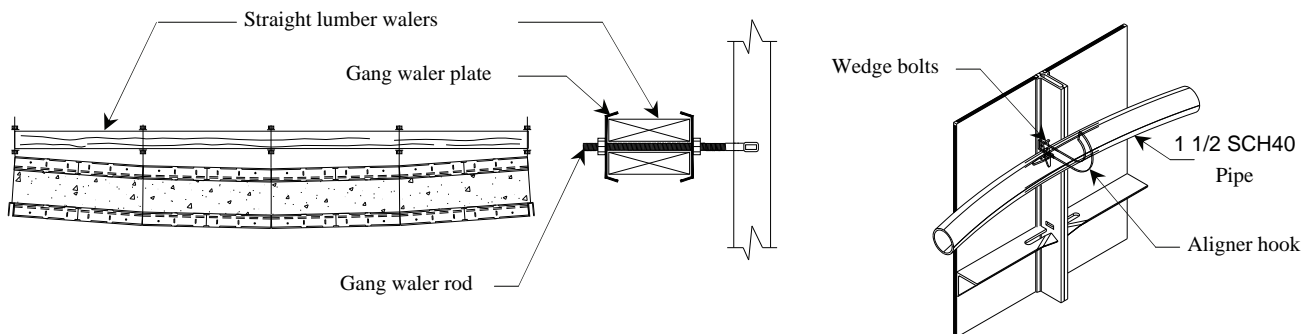

TIE SYSTEMS



HANDSET LOOP TIE

Standard 1" breakback. Available in standard and heavy-duty load ratings.



GANG LOOP TIE

Standard 1" breakback. Available in standard and heavy-duty load ratings.



BASE TIE

No breakback.



COMBINATION LOOP TIE

Standard 1" breakback. Handset and gang form ends.



SNAPTIE/ HANDSET LOOP TIE

Standard 1" breakback. For combination handset Uni-ply panel forming and job built wood forming.



SNAPTIE/ GANG LOOP TIE

Standard 1" breakback. For combination handset Uni-ply panel forming and job built wood forming.



THREADED LOOP TIE

Standard 1" breakback, loop end only. Available for Uni-ply handset and gang form applications.



HANDSET FLAT TIE

Standard 1/2" breakback. Available in standard and heavy-duty load ratings.

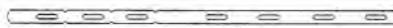

ADJUSTABLE FLAT TIE

Standard 1/2" breakback, one end only. Available in standard and heavy-duty load ratings.



NEOPRENE WATERSEALS

Optionally applied to ties to prevent the transmission of water down the length of the tie

TIE INFORMATION

LOOP TIE—STANDARD & HEAVY DUTY

The welded loop tie is designed for use with modular type panel form systems when hand set in place. It is fabricated from medium carbon wire and electrically welded to insure consistent safe working loads.

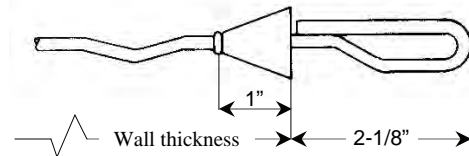
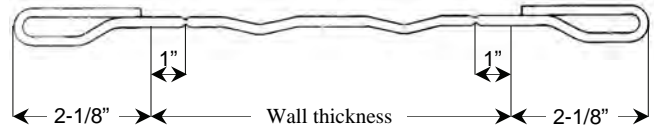

Also available with 1"x1" plastic cone

Capacity	Wire Size	S.W.L. (lbs.)
STD.	.225	2,250
H.D.	.243	3,000

Safety factor 2:1

GANG LOOP TIE—STD. & HEAVY DUTY

The gang loop tie differs from the standard loop tie in that it is used for gang forming modular systems.

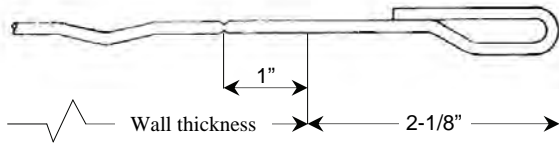

Capacity	Wire Size	S.W.L. (lbs.)
STD.	.225	2,250
H.D.	.243	3,000

Safety factor 2:1

"M" FLAT TIE

The "M" style flat tie is similar in application to the "X" flat tie.

Capacity	S.W.L. (lbs.)
STD.	3,000
H.D.	3,375

Safety factor 2:1

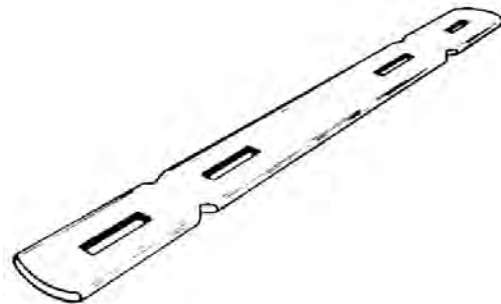

TIE INFORMATION

“X” FLAT TIES

The X flat tie is one of the more common methods of tying modular forming systems together. There are various patented form systems on the market that utilize this type of tie including the Uni-Form II system, and similar form systems.

Capacity	S.W.L. (lbs.)
STD.	3,000
H.D.	3,375

Safety factor 2:1

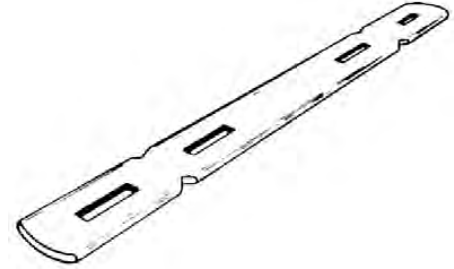
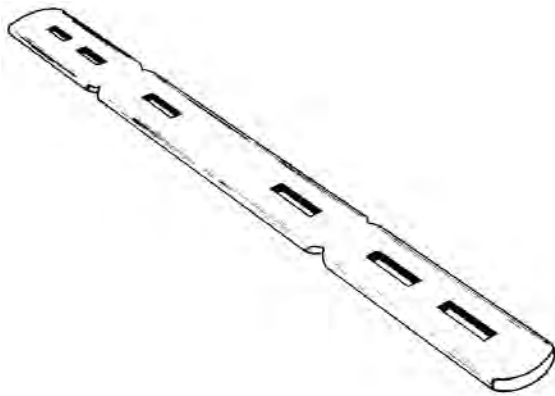

“DUO” FLAT TIE

The “duo” type flat tie is similar in design and application to the “X” flat tie. It differs in that it is fabricated with (2) slots outside the breakback. These additional slots allow for the combining of a pre-fab hand set system with a wood form.

Capacity	S.W.L. (lbs.)
STD.	3,000
H.D.	3,375

Safety factor 2:1

BASE TIE

The base tie is a 4 ga. Wire tie with ends sized to the slotted opening in a steel form. It is generally used to span across the base of two opposite steel forms for the purpose of establishing the desired wall thickness.



MISC. PART DESCRIPTION

LONG WEDGE BOLT

The long wedge bolt is similar in design to the standard wedge bolt. Its application differs only in that it allows for a filler to be placed between two panels. The added length of the long wedge bolt allows it to pass from one form thru the filler and thru the adjacent form with adequate room to lock the bolt in place by use of a regular wedge bolt.

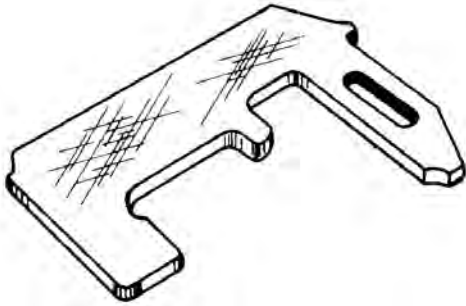
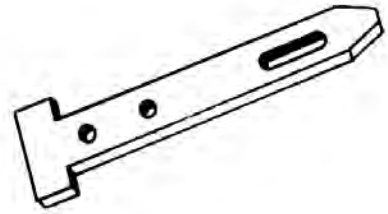

GANG FORM BOLT

The gang form bolt is also made of high strength heat-treated steel. Its purpose is to convert a hand-set system to a gang-form system utilizing a loop tie with a gang form end.

“S” WEDGE

The “S” wedge is a multi-purpose wedge used to secure ply-lag ends or other similarly slotted hardware items to the steel forms.

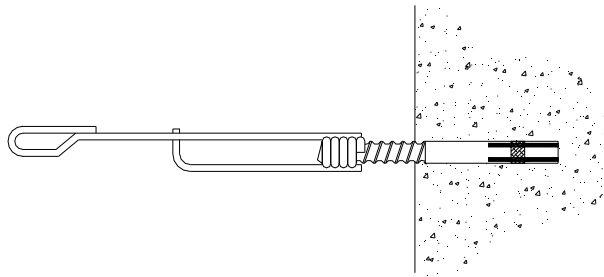
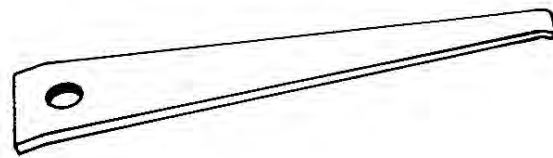

COMBO TIE

The combo tie is used to tie a uni-ply form to an existing structure. In the example shown here we have a piece of coil rod inserted into a drop-in coil anchor. The combo tie simply screws onto the coil rod.

MISC. PART DESCRIPTION

WALER TIE

The waler tie is fabricated from 4 ga. high strength wire with welded loop ends positioned on 90° planes to each other.

It's main function is to tie a z-tie holder and the double wales to the steel forms when the wales are running horizontally.



STRONGBACK TIE

The strongback tie is fabricated from 4 ga. high strength steel with welded loop ends. Similar in use to a waler tie, it is used to attach a z-tie holder and double wales to the steel forms when the wales are running vertically.

PLY-LAG

The ply lag is a 1/2" coil threaded rod, flattened on one end and slotted to fit between two steel forms. The protruding threaded rod is then utilized to attach a waler plate (see detail).

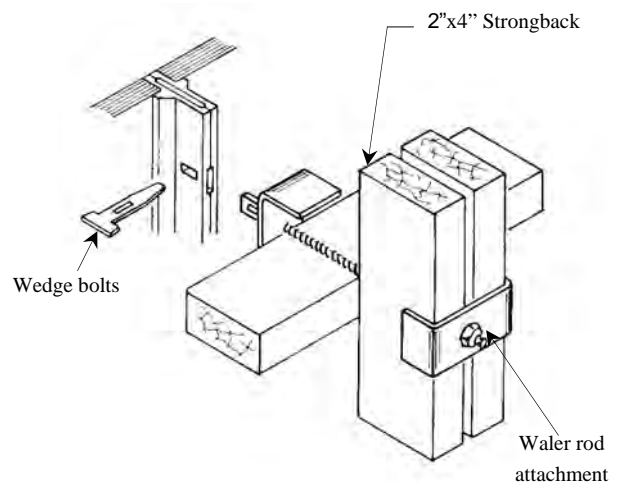
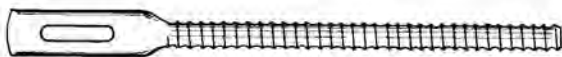

GANG FORMING

Large sections of uni ply forms are assembled first, then crane moved into position to pour a wall section. Gang forming uses the same basic hardware as hand set, but offers great advantages to contractor. Gangs are easily assembled on ground, they strip as a unit, they are reusable without disassembly for more pours, they are light approx 7 lbs per sq ft assembled.

Gangs are assembled by placing panels face down on a flat surface. The horizontal walers are laid out to fall below the horizontal joints the wedge bolt connections are made 6" from corner and 6" from mid point of side rail.

Walers and stiff backs are usually 2"x4" but can also be 2"x6" or 2"x8". The total depth between waler and stiff back should not exceed 12". Since the wooden waler and stiff back are used for alignment only few are required, but they should be located as not to infer eith tie placement. They are attached with one of the following methods gang waler rods or J-strong back rod.

Double duty lift bracket provides a attachment point for lifting rigging it attachment directly to panel insertions with wedge bolt, and has a 2000 lbs rated capacity.

The real key to ganging is the gang form tie and gang form bolt. The tie length is extend past the form edge to allow you to break of ties with out disassembling gang units.

The gang tie is inserted and passed through both opposite panels and one end locked using gang form bolt. It is important that the gang form bolt be inserted and latched properly. Remember that if the short end of welded wire loop faces up insert bolt from left, if it faces down insert from right. Also if after locking one end you find the opposite end sticking out past or short of panel slot do not hammer or force bolt, welds can be damaged or cracked without any sign and could cause a tie failure.

What SureBuilt considers heavy gang forming with uni-ply forms is a gang system that utilizes taper ties, she bolts and inner rods coupled with the use of all steel channel system of walers and stiff backs. The use of both 3" horizontal channel and either 5" or 8" stiff back allows for the use of heavy tie systems at greater spacing. The panel plywood does have to be drilled to allow tie to pass through to make connection to opposite gang, and you have to decrees the spacing of 3" dbl channel walers to 2'-0" O/C.

STRIPPING FORMS

Usually form stripping can begin after all connecting hardware has been removed. It is easiest to begin at a relief point such as an outside corner, metal filer or filer angle connection.

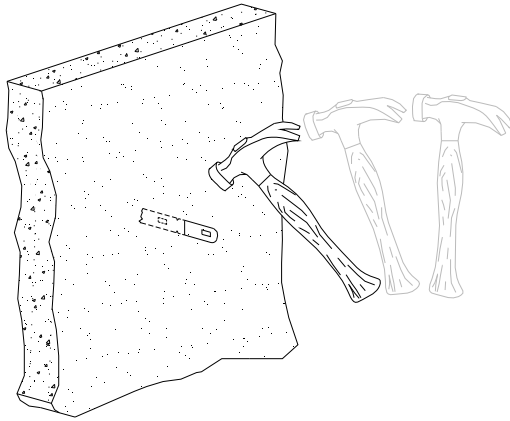

On flat ties simply stroke and strike on side. Ties will break right off.

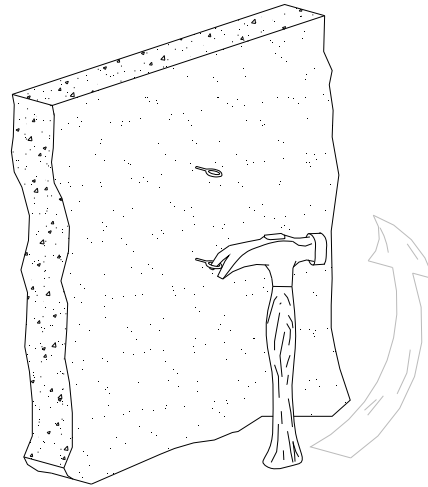

To break wire ties simply twist loop 3/4 of a turn and they will break off.

Gang form ties are just as easy to remove. First, remove the gang form bolt. Then, twist the wire tie as described above and remove stub.

It is recommended that with gang ties you begin removing them at lowest level and work your way upwards. This insures that the form is always secured while workers are on or near the gang.

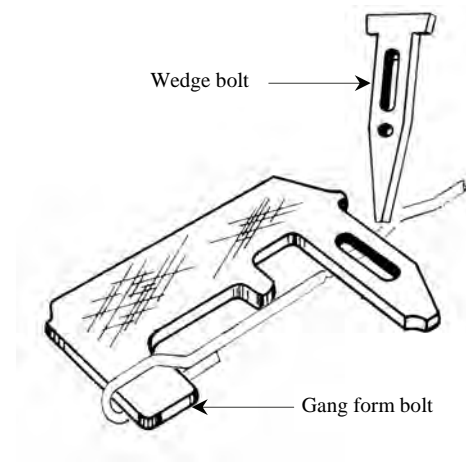

SAFETY NOTE: *All the proper safety equipment should be worn during stripping to prevent personal injury.*

INDEX

- | | | | |
|-----|-------------------------------|----|----------------------------|
| 12 | ADJUSTABLE TURNBUCKLE ALIGNER | 7 | ONE PIECE WALER CLAMP |
| 12 | ATTACHMENT PLATE | 23 | OUTSIDE CORNER |
| 29 | BASE TIE | 23 | OUTSIDE HINGE CORNER |
| 23 | BAY CORNER | 18 | PILASTER BRACE |
| 21 | BRICK LEDGE BRACKET | 18 | PILASTER DESIGNRADIUS WALL |
| 20 | BULKHEAD FORMING | 17 | PILASTER FORM |
| 21 | CANTILEVER BRACKET | 31 | PLY-LAG |
| 30 | COMBO TIE | 26 | RADIUS WALL |
| 20 | CONSTRUCTION JOINTS | 8 | ROLLED STEEL WALERS |
| 25 | CULVERT FORM | 13 | SAFETY EYE |
| 29 | DUO FLAT TIES | 13 | SCAFFOLD BRACKETS |
| 14 | FILLER PANELS | 11 | SECOND VERTICAL POUR |
| 14 | FILLERS | 5 | SETTING PANELS |
| 19 | FOOTINGS | 19 | SLOPE FOOTING |
| 12 | FORM ALIGNMENT | 10 | STACKING FORMS |
| 30 | GANG FORM BOLT | 19 | STEP FOOTING |
| 32 | GANG FORMING | 33 | STRIPPING FORMS |
| 28 | GANG LOOP TIE | 31 | STRONGBACK TIE |
| 26 | GANG WALER PLATE | 9 | STRONGBACK Z-TIE HOLDER |
| 8,9 | GANG WALER ROD ASSEMBLY | 9 | STRONGBACKS |
| 23 | INSIDE HINGE CORNER | 30 | S-WEDGE BOLT |
| 14 | JOB BUILT FILLERS | 16 | TIE OFFSETS |
| 9 | J-STRONGBACK DETAIL | 27 | TIES |
| 8 | J-WALER | 31 | WALER TIE |
| 30 | LONGE WEDGE BOLT | 7 | WALERS |
| 28 | LOOP TIE | 16 | WALL INTERSECTIONS |
| 14 | METAL FILLERS | 29 | X-FLAT TIE |
| 28 | M-FLAT TIE | 7 | Z-TIE HOLDER |
| 12 | MINI BRACE ALIGNER | | |

LIMITED WARRANTY

SureBuilt Concrete Forms & Accessories (hereafter known as Supplier) warrants that the Supplier of concrete accessory products sold to Purchaser will be free from defects in materials and workmanship for a period of six (6) months from the date of delivery, and the Supplier will repair, or in its sole discretion, replace, any Product or part thereof found to be defective at the time of delivery if such Product or part is returned (at Purchaser's expense and risk) and received by the Supplier within ten (10) days after the applicable warranty period. Descriptions, representations and other information concerning the Supplier contained in the Supplier's catalogs, advertisements or other promotional materials or statements or representations made by the Supplier's sales agents or representatives shall not be binding upon the Supplier and shall not be part of this limited warranty unless expressly identified in writing as PRODUCT SPECIFICATIONS.

This limited warranty does not cover normal maintenance, or items consumed during installation or normal operations, normal wear and tear, use under circumstances exceeding specifications, use for purposes other than the use for which the Products were intended, abuse, unauthorized repair or alteration, improper installation, failure to follow the Supplier's printed instructions, guidelines and recommendations for installation and use, lack of proper maintenance or damage caused by natural causes such as fire, storm, or flood. Purchaser shall determine the suitability of the Product for his intended use and Purchaser assumes all liabilities and risks whatsoever in connection therewith.

This limited warranty is Purchaser's exclusive remedy. It shall not be deemed to have failed of its essential purpose so long as the Supplier is willing and able to repair or replace defective products or parts thereof in the manner specified. No allowance will be made or repairs made by Purchaser.

Except as herein provided, the Supplier shall not be liable to Purchaser in any manner with respect to the Products. In no event shall the Supplier liability to Purchaser ever exceed the purchase price of the allegedly defective Product. Except as herein provided, the Supplier shall not be liable for transportation, labor or other charges for adjustments, repairs, replacements of parts, installation, or other work, which may be done upon or in connection with the Products sold.

THE SUPPLIER SHALL NOT IN ANY EVENT BE LIABLE FOR INCIDENTAL OR CONSEQUENTIAL DAMAGES OF ANY NATURE WHATSOEVER, INCLUDING LOST PROFITS, whether arising from any defect in the Products, any use of the Products, from Purchaser's inability to use the Products, or otherwise. This limited warranty applies to only products made by the Supplier.

NO OTHER EXPRESS AND NO IMPLIED WARRANTIES OF ANY TYPE, WHETHER FOR MERCHANTABILITY, FITNESS FOR A PARTICULAR USE, OR OTHERWISE, OTHER THAN THOSE EXPRESSLY SET FORTH ABOVE (WHICH ARE MADE EXPRESSLY IN LIEU OF ALL OTHER WARRANTIES) SHALL APPLY TO THE PRODUCTS.

SureBuilt

Concrete Forms & Accessories

840 SOUTH 25TH AVE • BELLWOOD IL 60104

PHONE 708.493.9569 • FAX 708.493.9601

WWW.SUREBUILT-USA.COM