

Weld-On Pivot Bracket

Designed to provide tie rod adjustment in one-sided forming applications

The Weld-On Pivot Bracket can be attached to steel construction members, including steel piles, metal beams and weld plates, by following proper welding techniques. The pivot bar is typically furnished with coil thread, euro thread is available on request.

The Weld-On Pivot Bracket allows the tie rod to pivot a total range of 110°, or 55° in either direction to tie with forms. The bracket exceeds the tensile capacity of the pivot bar or threaded tie rod being used when properly installed by a certified welder.

To insure proper engagement the threaded tie rod must pass through the pivot bar a minimum of one diameter of the rod. An easy way to accomplish this is to position the tie rod perpendicular to the piling and thread it through the pivot bar until it comes in contact with the piling.



The Weld-On Pivot Bracket consists of a bent plate and pivot bar with threaded hole. The threaded tie rod to match the forming condition is sold separately.

Weld-On Pivot Bracket

Part No.	Description	Tie Rod Diameter	SWL* (lbs)	Wt. (lbs)
SBWOPB12	Weld-On Pivot Bracket 1/2" Set	1/2"	9,000	2.9
SBWOPB58	Weld-On Pivot Bracket 5/8" Set	5/8"	12,000	3.2
SBWOPB34	Weld-On Pivot Bracket 3/4" Set	3/4"	18,000	3.2
SBWOPB1	Weld-On Pivot Bracket 1" Set	1"	31,500	7.2
SBWOPB114	Weld-On Pivot Bracket 1-1/4" Set	1-1/4"	38,250	13.4
SBWOPB15MM	Weld-On Pivot Bracket 15MM Set	15 mm	22,400	2.7
SBWOPB20MM	Weld-On Pivot Bracket 20MM Set	20 mm	39,200	7.1

* Safe Working Load (SWL) based on 2:1 safety factor.
(Dependent on the quality of field weld, materials, and thread engagement inside pivot bar.)

Application

By welding both edges to a steel construction member, the Weld-On Pivot Bracket is secure and the threaded tie rod may be adjusted to the required angle.

All previously stated Safe Working Loads are based on full welds of the bracket plate thickness to a cleaned carbon steel surface in accordance with American Welding Society (AWS) standard welding procedures.

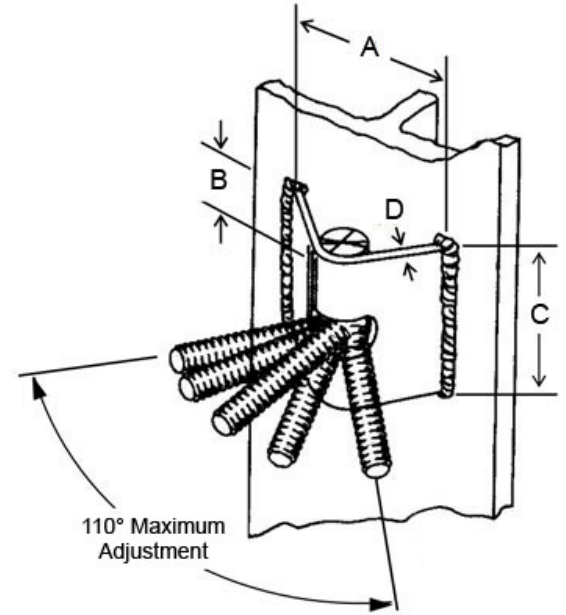

Weld-On Pivot Bracket Dimensions

Coil Rod	A	B	C	D
1/2"	6"	2-1/4"	3-1/4"	1/4"
5/8"	6"	2-1/4"	3-1/4"	1/4"
3/4"	6"	2-1/4"	3-1/4"	1/4"
1"	6"	3-1/16"	5"	3/8"
1-1/4"	6"	3-1/16"	5"	3/8"
15MM	6"	2-1/4"	3-1/4"	1/4"
20MM	6"	3-1/16"	5"	1/4"

